

ISOMETRIC ACTUAL SIZE

FRONT VIEW

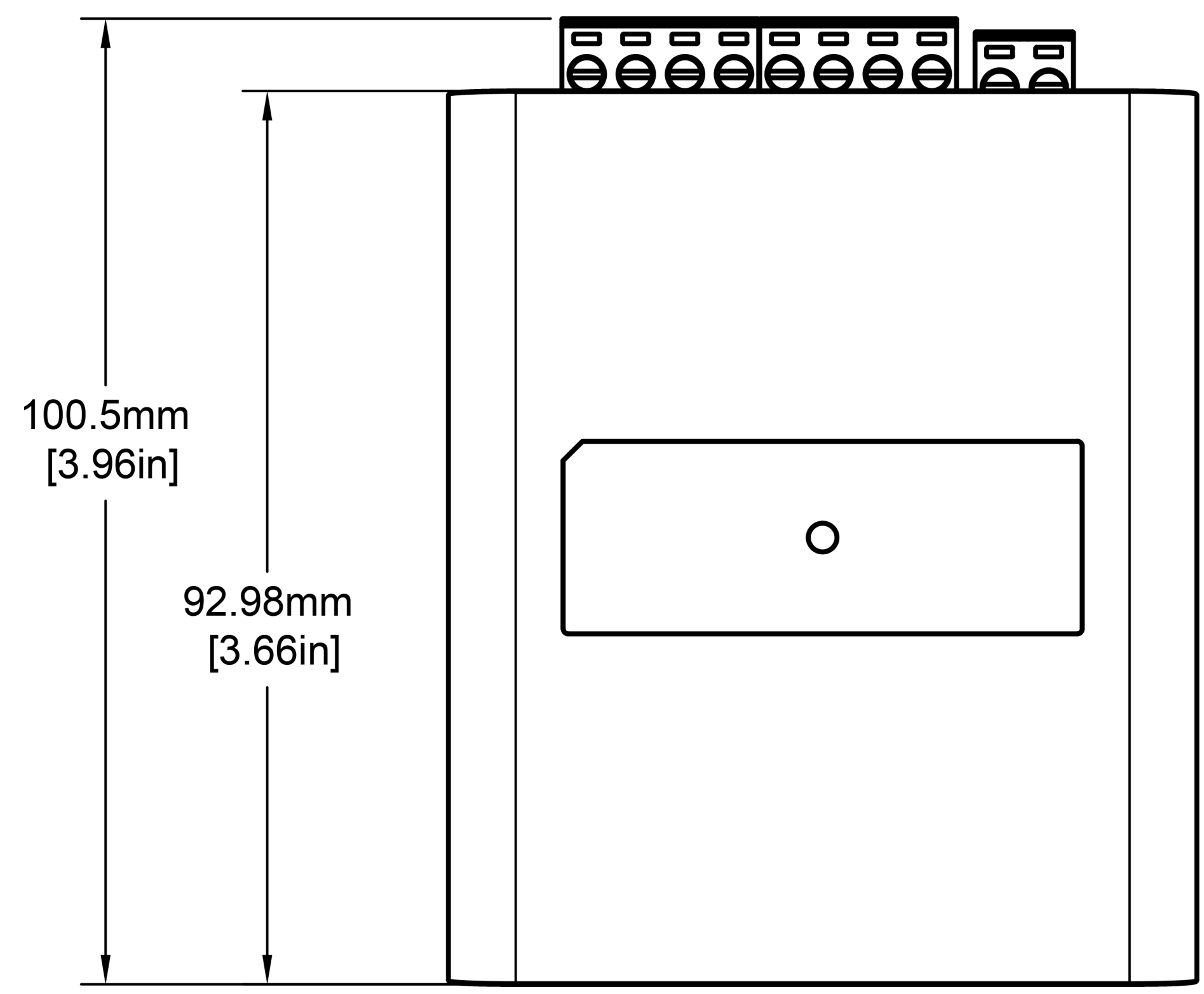

BACK VIEW

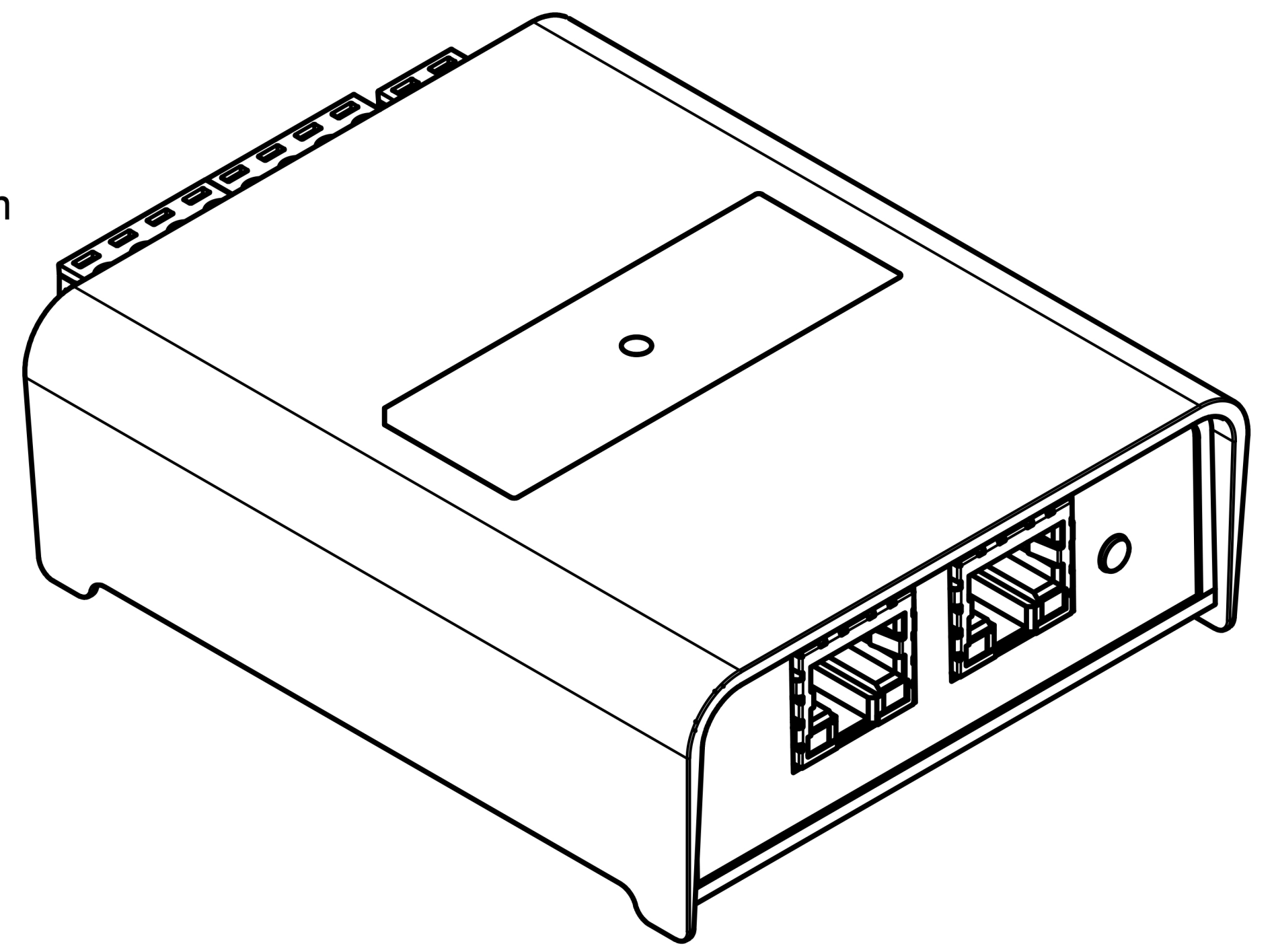
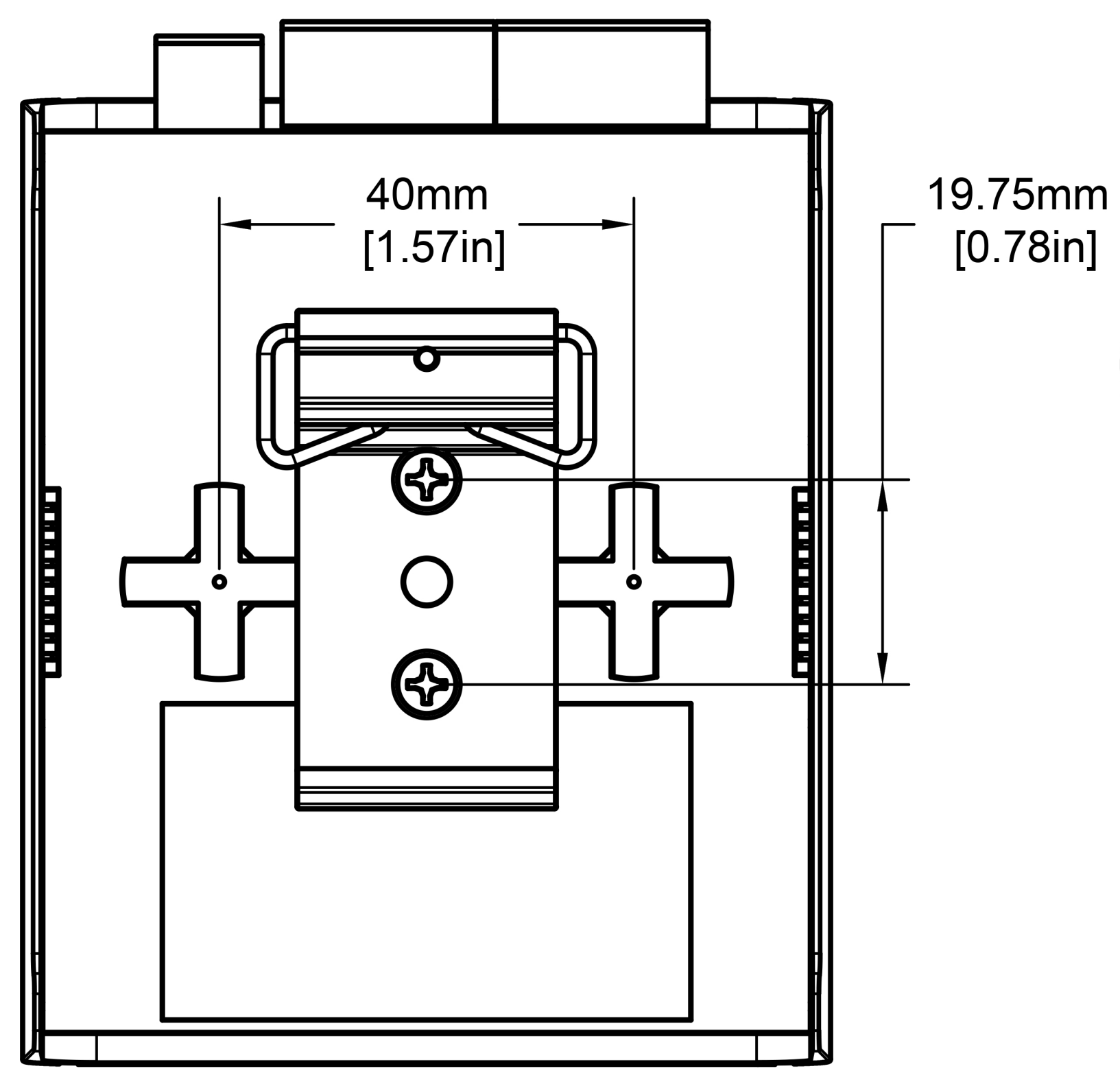

BOTTOM VIEW

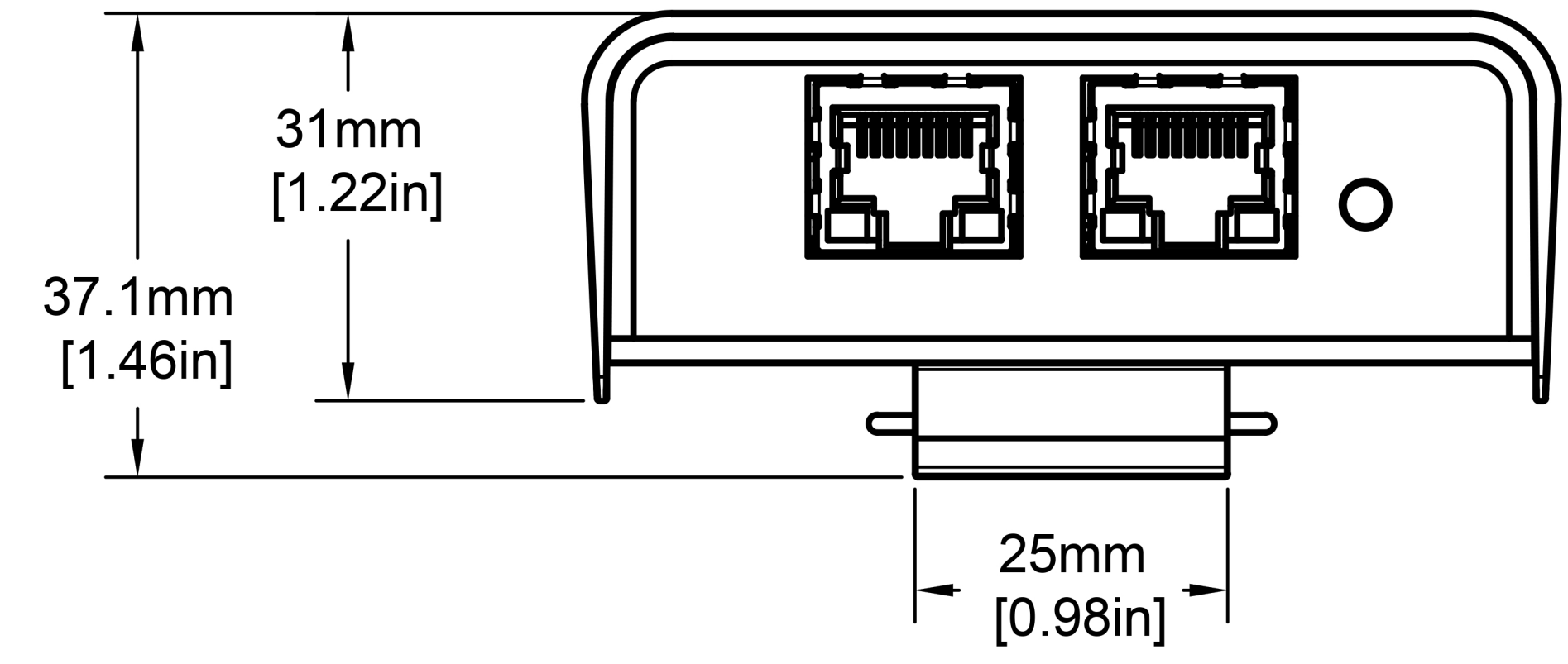

TOP VIEW

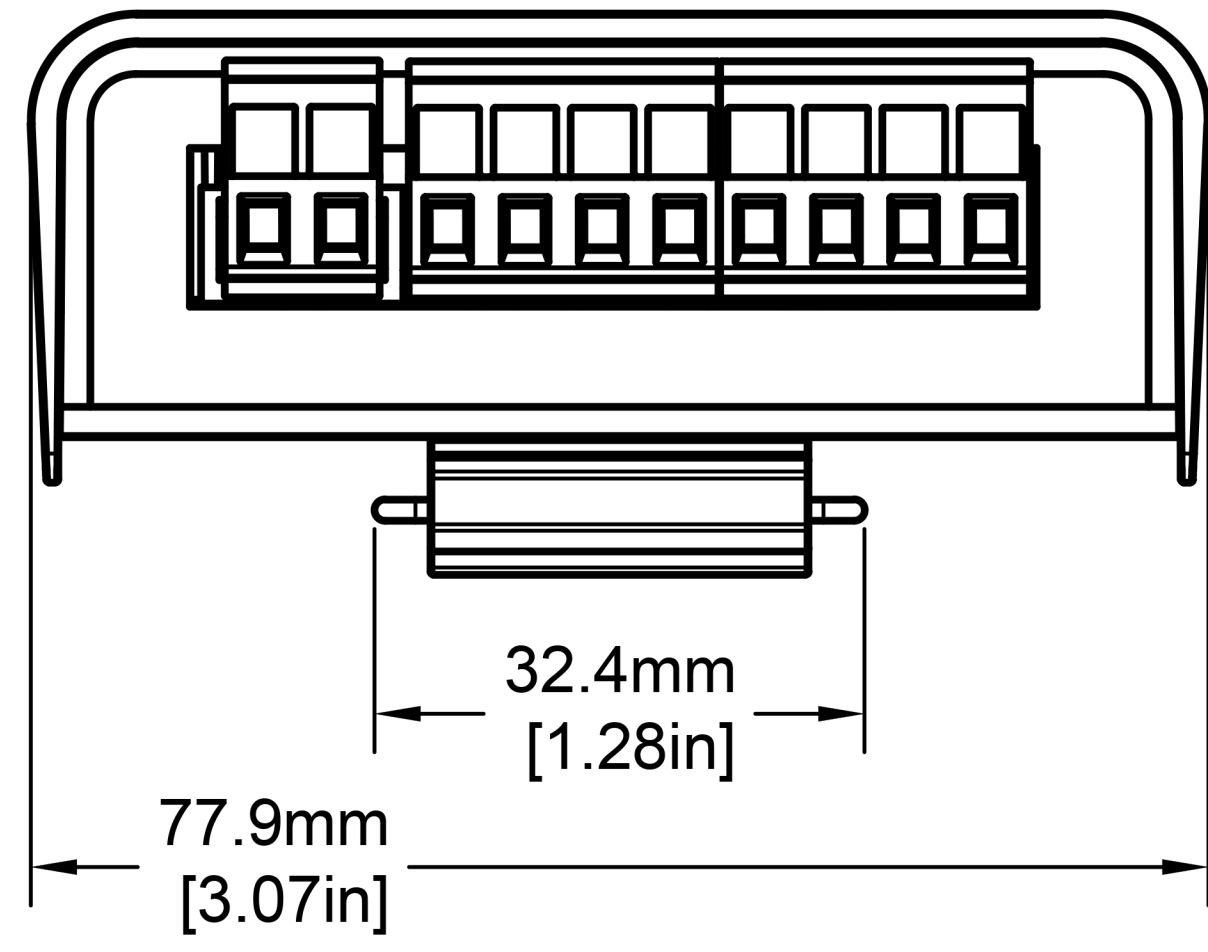

SIDE VIEW

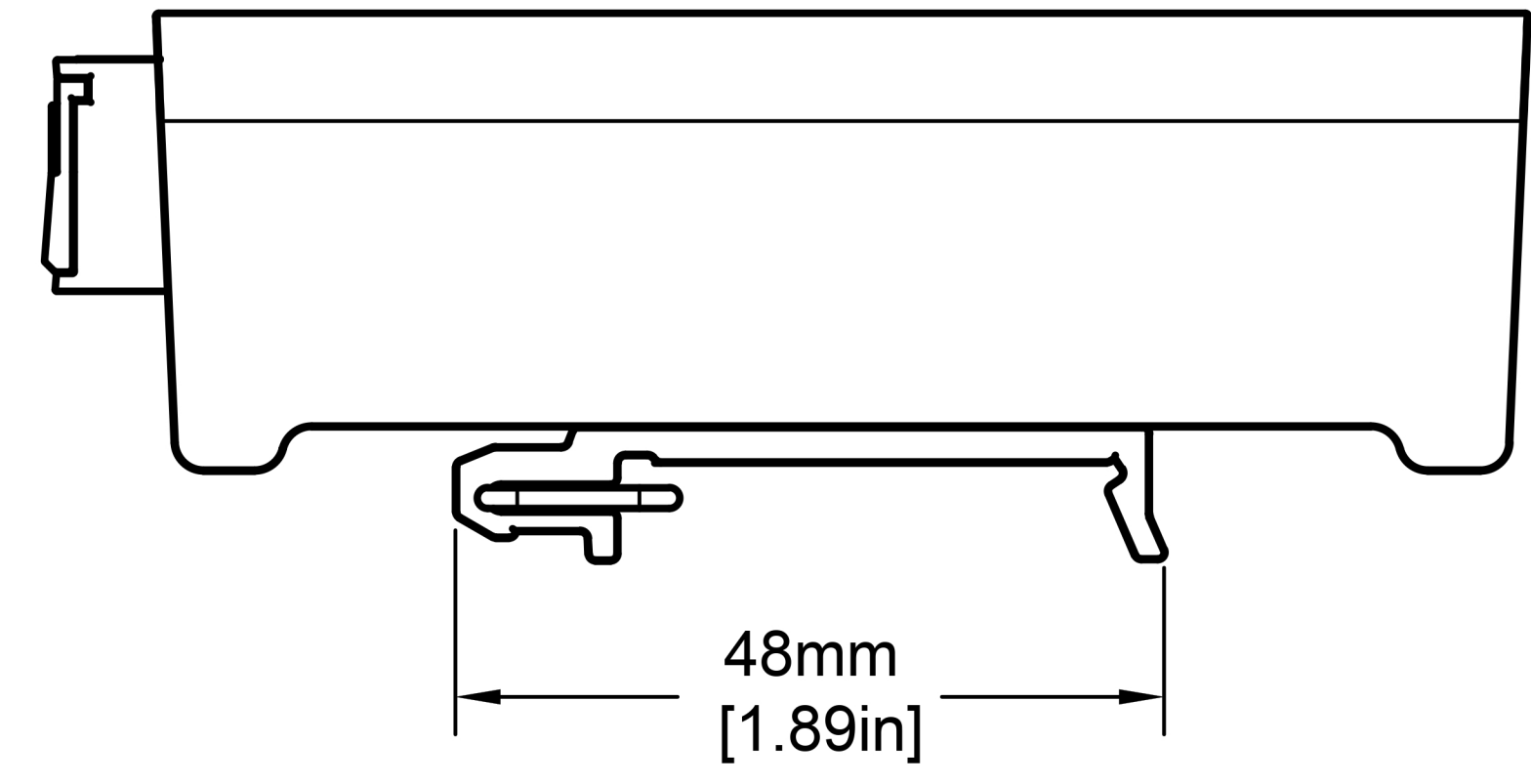

1	RELEASED FOR PRODUCTION	ROC	15-12-20				
ISSUE	REVISION	DCN / INITIAL	9-12-20	ISSUE	REVISION	DCN / INITIAL	DATE

MATERIAL & FINISH
PLASTIC, BLACK

TOLERANCES
(UNLESS OTHERWISE SPECIFIED)
0.1 UP TO 6mm IS ±0.05
OVER 6 UP TO 30mm IS ±0.10
OVER 30MM UP TO 120mm IS ±0.25
OVER 120MM TO 400mm IS ±0.50
OVER 400mm IS ±1.00
ANGULAR IS ±1/2°

	INITIAL	DATE
DRAWN	ROC	9-12-20
CHECKED	JW	15-12-20
SCALE	1:1	
TITLE		

THIS DOCUMENT AND THE DESIGN IT CONTAINS IS EXCLUSIVELY THE PROPERTY OF ENTTEC AND IS THE SUBJECT OF COPYRIGHT

DRAWN TO AS1100
ALL DIMENSIONS IN MILLIMETERS
DO NOT SCALE - IF IN DOUBT ASK

ENTTEC
enttec.com

OCTO EXTERIOR DIMENSIONS

A3

ISOMETRIC ACTUAL SIZE

**MOUNTING METHOD 1:
DIN RAIL MOUNT**

ATTACH DIN RAIL CLIP
USING THE 2 SCREWS PROVIDED
WITHIN THE PRODUCT PACKAGING.
ATTACH UNIT TO A SUITABLE TS35 RAIL.

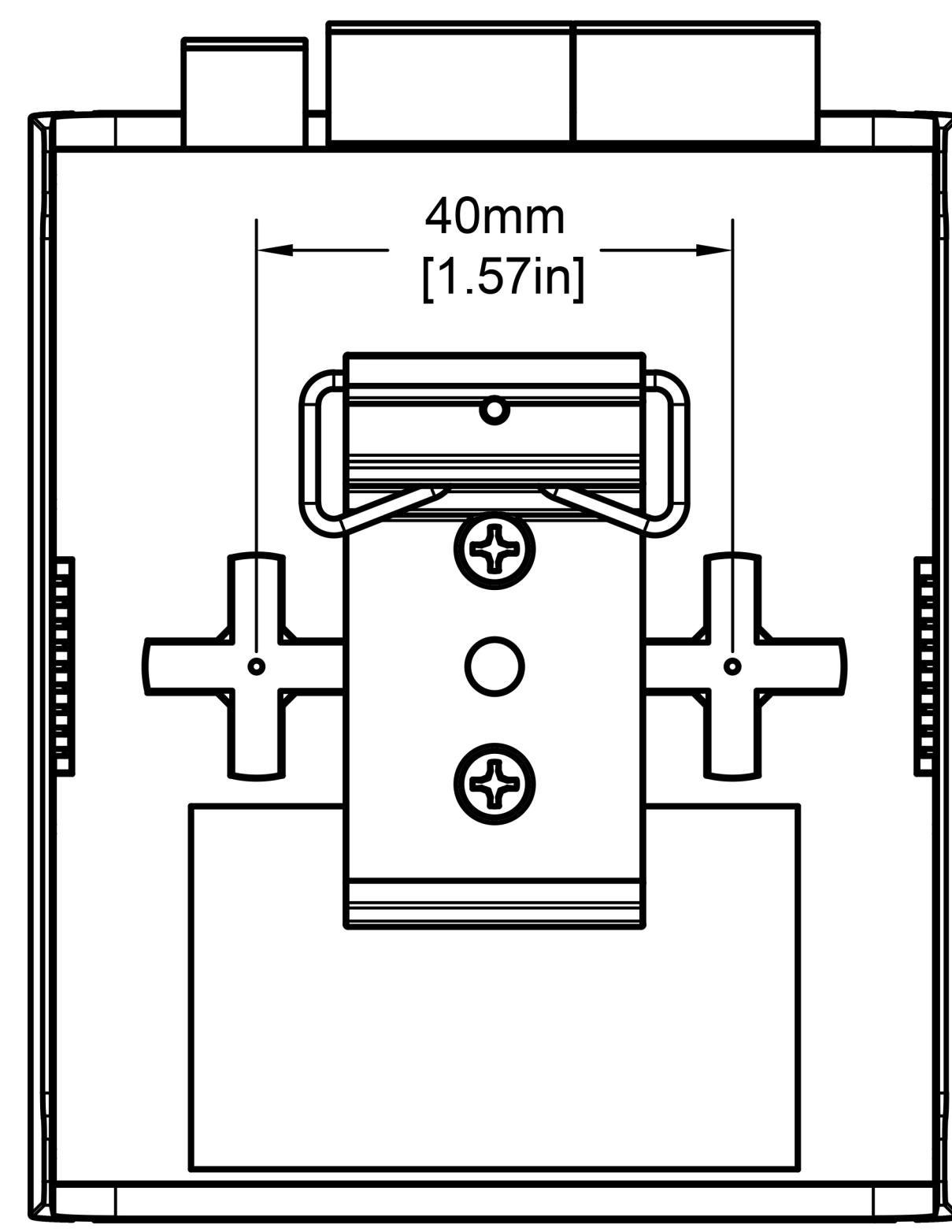

**MOUNTING METHOD 2:
WALL/PANEL MOUNT**

REMOVE DIN CLIP IF ATTACHED.
SPACE 2X M3 SCREWS 40MM APART
HORIZONTALLY AND ATTACH TO TARGET SURFACE.
MOUNT UNIT TO EXPOSED M3 SCREW HEADS
SLIDE DOWN TO LOCK.

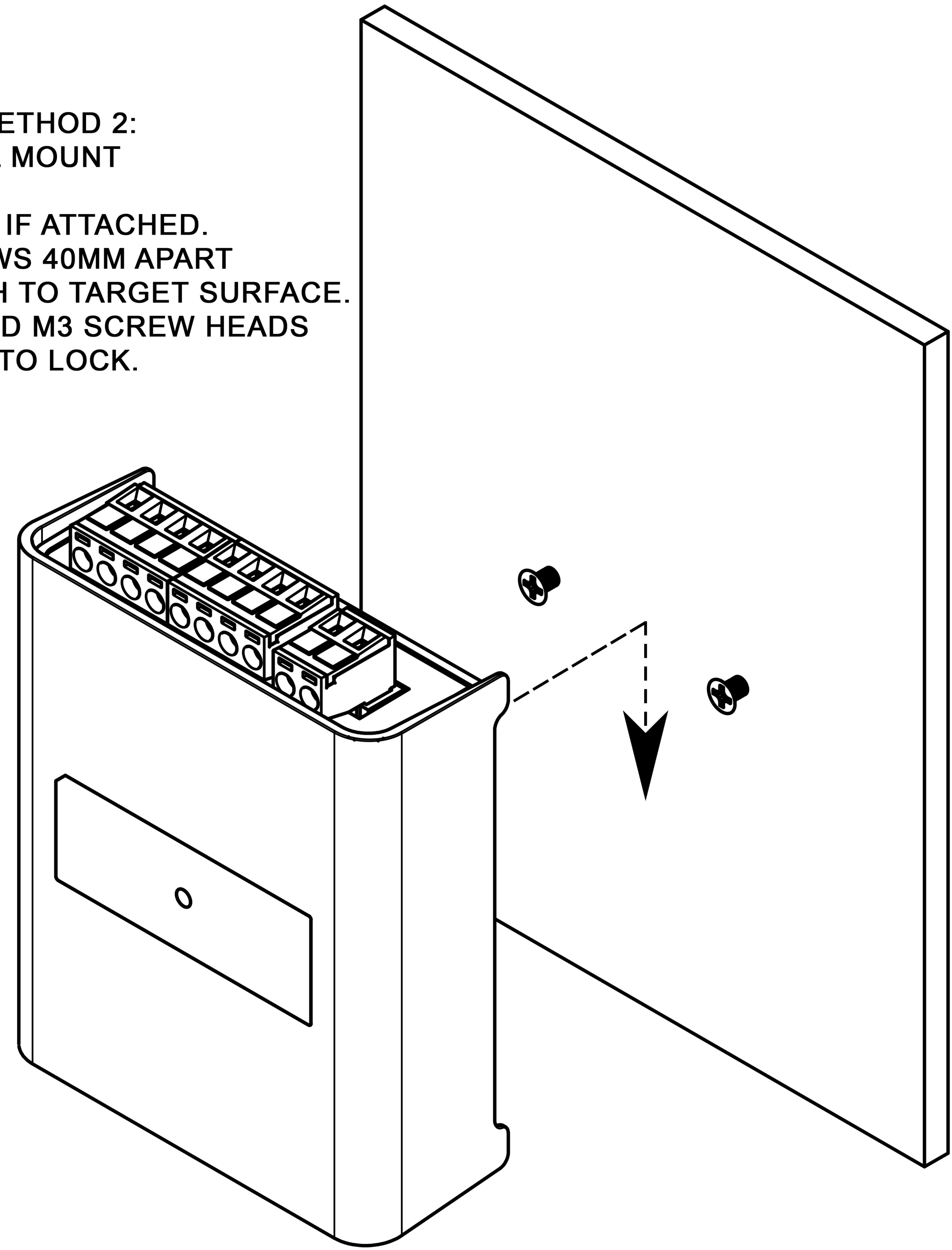
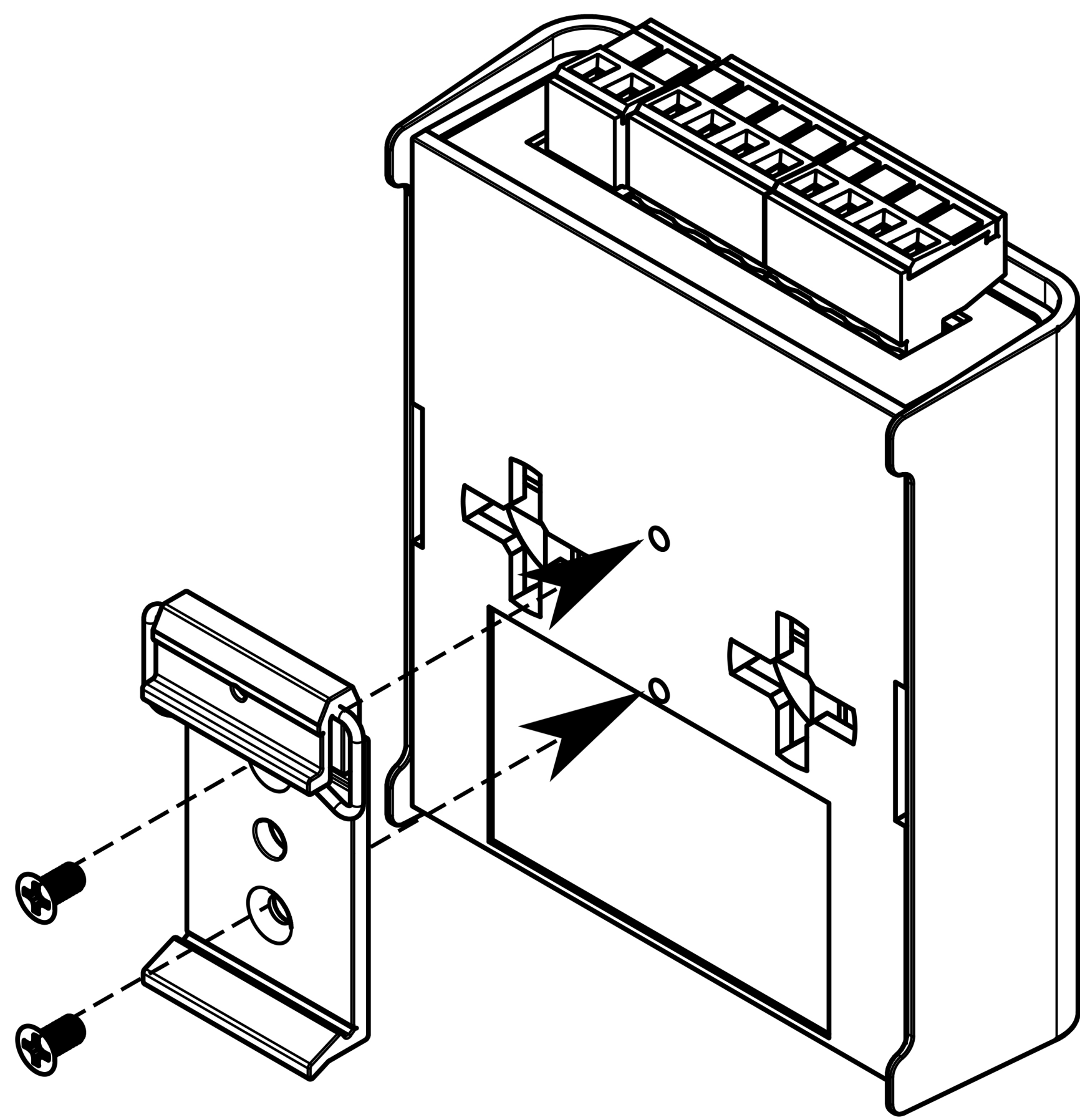

1	RELEASED FOR PRODUCTION	ROC	15-12-20						
ISSUE	REVISION	DCN / INITIAL	DATE	ISSUE	REVISION	DCN / INITIAL	DATE		

MATERIAL & FINISH	PLASTIC, BLACK
TOLERANCES (UNLESS OTHERWISE SPECIFIED)	0.1 UP TO 6mm IS ±0.05 OVER 6 UP TO 30mm IS ±0.10 OVER 30MM UP TO 120mm IS ±0.25 OVER 120MM TO 400mm IS ±0.50 OVER 400mm IS ±1.00 ANGULAR IS ±1/2°

DRAWN	ROC	DATE	11-12-20
CHECKED	JW	DATE	15-12-20
SCALE	1:1		
TITLE			
OCTO MOUNTING DIAGRAMS			

THIS DOCUMENT AND THE DESIGN IT CONTAINS IS EXCLUSIVELY THE PROPERTY OF ENTTEC AND IS THE SUBJECT OF COPYRIGHT
DRAWN TO AS1100
ALL DIMENSIONS IN MILLIMETERS
DO NOT SCALE - IF IN DOUBT ASK

ENTTEC
enttec.com

A3